

REV	MODIFICATION	DATE	DRN
A	PRELIMINARY DRAWING	30/6/24	MT

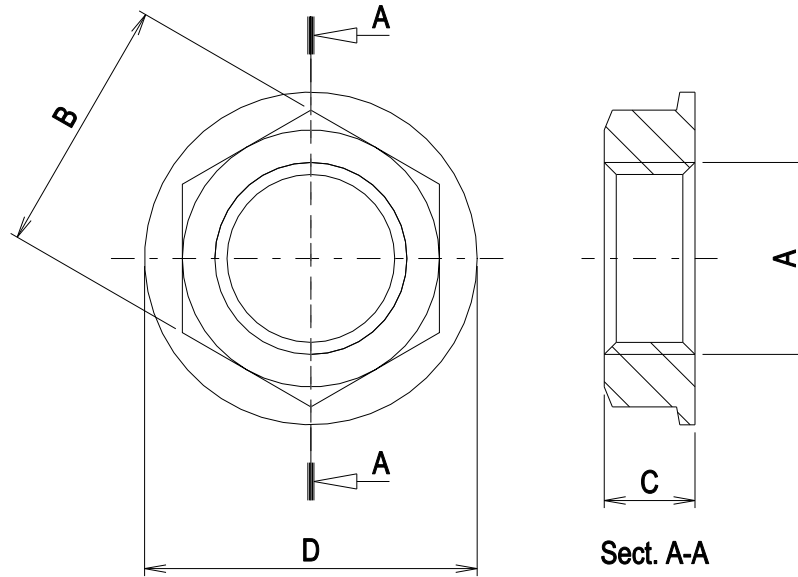

A	THREAD SIZE
B	ACROSS FLATS
C	THICKNESS
D	FLANGE DIAMETER

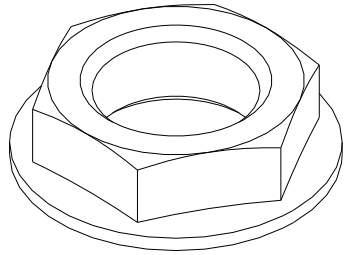

DESCRIPTION: BACK NUT		COLOUR: NATURAL	
MATERIAL: NYLON		PART NUMBER:	
DRAWING NO:		SHEET SIZE: A4	
DRAWN: MT	DATE: 30/6/24	CHECKED:	DATE:
SCALE: 1:1		SHEET NO. 1 OF 1	

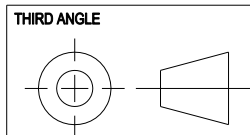

INFORMATION CONTAINED IN THIS DOCUMENT IS CONFIDENTIAL TO ALLTHREAD PLASTICS LTD AND MAY NOT BE DISCLOSED OR REPRODUCED IN WHOLE OR IN PART WITHOUT THEIR WRITTEN CONCENT